

TECHNICAL DATA SHEET

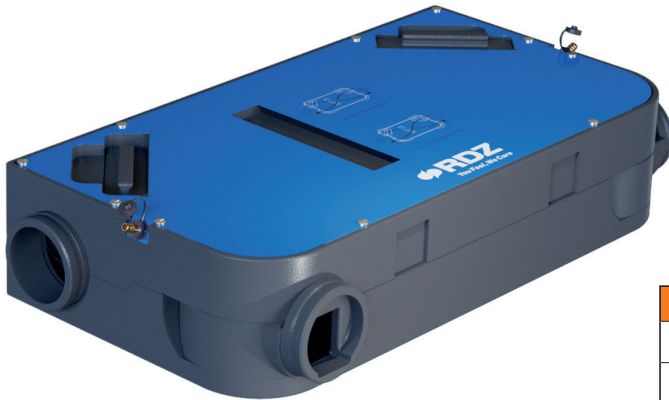

| Description | Sizes (wxhxd) | Weight | Code |
|-------------|-----------------|--------|------------|
| REFLAIR 150 | 1100x240x580 mm | 22 kg | 70RFL00150 |
| REFLAIR 250 | 1100x240x580 mm | | 70RFL00250 |

Reflair is an high-efficiency ductable mechanical ventilation unit with heat recovery, designed for residential use. It can be installed either in the false ceiling or on the wall. Adjustable and configurable connections ensure a constant pressure drop and reduce the number of connections required. The construction in sintered expanded polypropylene thermally insulates the internal components and makes the unit extremely light. Thanks to its compact dimensions, it can be installed in spaces of reduced height. REFLAIR can be integrated and managed control panels integrated into the CoRe regulation system, or controlled via digital inputs.

PRINCIPLES OF OPERATION

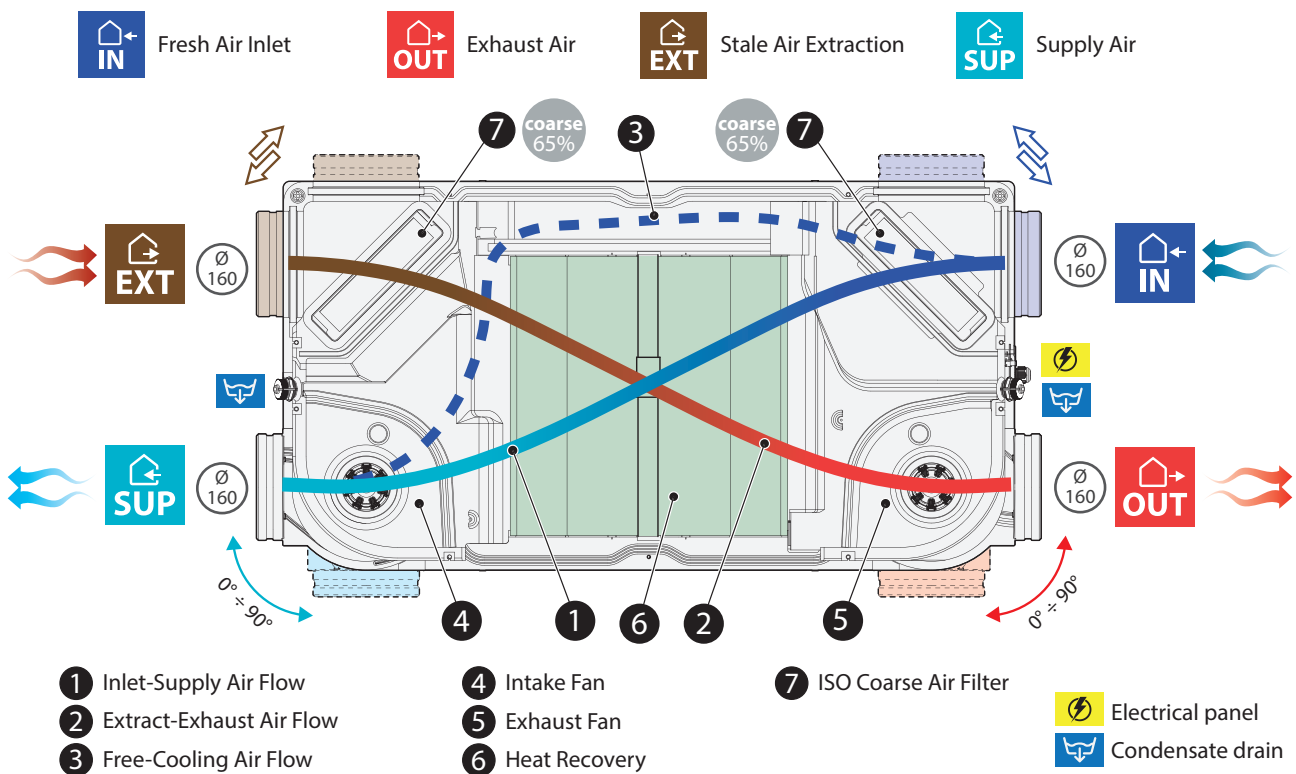

- Balanced ventilation unit with heat recovery;
- Wall and false ceiling installation;
- High-efficiency heat recovery with countercurrent flows;
- EPP body to increase thermal and acoustic insulation and reduce the weight of the unit;
- Centrifugal fans with constant flow EC motor;
- 4 NTC sensors for air temperature monitoring;
- ISO Coarse 65% (G4) filters as standard;
- ISO ePM1 60% (F7) filters optional;
- Operating modes: manual, schedules, economy, boost, free-cooling;
- Room controllers: CoRe AIR SPEED, CoRe AIR CONTROL, CoRe AIR 3V, IAQ probes;
- Other control options: CoRe System, digital inputs, 0-10V signal, Modbus;
- No. 1 Condensate drain kit (SF-M, SF-P N) mandatory;

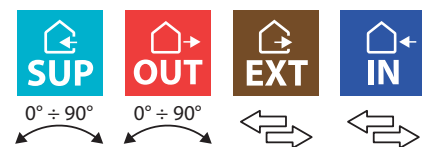

Packaging composition

- Mechanical ventilation unit;
- Installation template for brackets;
- Brackets for ceiling or wall mounting;
- Instruction manual for installation, start-up and maintenance;

Materials

- Sintered expanded polypropylene and pre-painted steel;

TECHNICAL DATA SHEET

DIMENSIONS

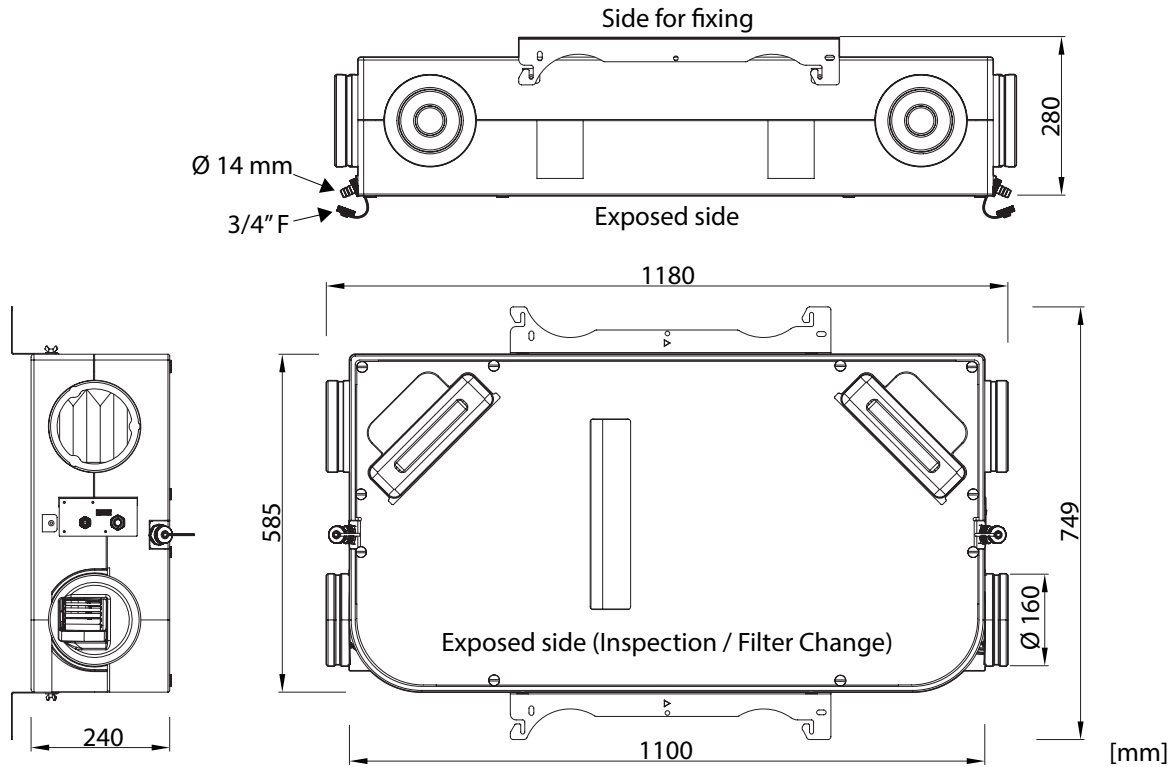

UNIT CONTROL MODES

CHARACTERISTICS

- Wall installation on built-in box 502/503 or Ø 60 mm
- Power supply 12 VDC (power supply unit required)
- Bus cable 2x0.5 mm² twisted and shielded
- Power consumption max. 60 mA
- R-BUS port
- Devices for indoor application

CoRe Air Speed



Room control for displaying and setting the unit's operation.

CoRe Air Control

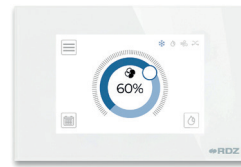

Room control for managing operating modes, time schedules and parameters of the unit.

CoRe Air 3v



Room control for displaying and setting the operation of the controlled mechanical ventilation unit.

INTEGRATION INTO CONTROL SYSTEM

Reflair can be integrated into RDZ CoRe System or within in systems with Modbus or KNX protocol.

| Accessories / Complements | | Code |
|---------------------------|--------------------|------------|
| ROOM CONTROLLER | CORE AIR SPEED | 7041476 |
| | CORE AIR CONTROL | 7041477 |
| | CORE AIR 3V | 7141478 |
| | INTERFACE KNX-UTA | 7041480 |
| AIR FILTERS KIT | REFLAIR 150/250 G4 | 70RFLG4000 |
| | REFLAIR 150/250 F7 | 70RFLF7000 |
| CONDENSATE DRAIN KIT (*) | SF-M 13 | 3600401 |
| | SF-P N | 7045504 |

| REFLAIR 150 Optional | | Code |
|------------------------|-------------|---------|
| STD ELECTRIC HEATER | RE-S 05-125 | 7045565 |
| WATER BATTERY | BA-P 6 | 7045598 |
| | BA-P 10 | 7045599 |
| MODULATING VALVE Ø ½" | | 7045562 |

| REFLAIR 250 Optional | | Code |
|---------------------------|--------------|---------|
| STD ELECTRICAL RESISTANCE | RE-S 075-160 | 7045567 |
| WATER BATTERY | BA-P 6 | 7045598 |
| | BA-P 10 | 7045599 |
| MODULATING VALVE Ø ½" | | 7045562 |

(*) It si mandatory install nr. 1 condensate drain kit.

TECHNICAL DATA SHEET

CORE SYSTEM R-BUS NETWORK CONNECTIONS

The communication cable between the various nodes is a 2 x 0,5 mm² twisted and shielded cable, entry-exit connection. The shielding must be connected by creating continuity between the various pieces of cable and grounded at a single point in the network. It is possible to connect several probes to the same Reflair unit.

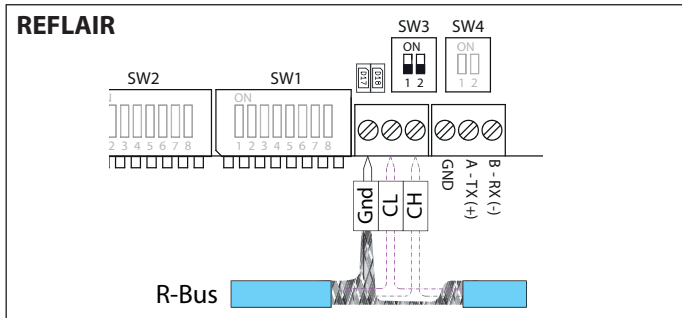

CONNECTION EXAMPLES

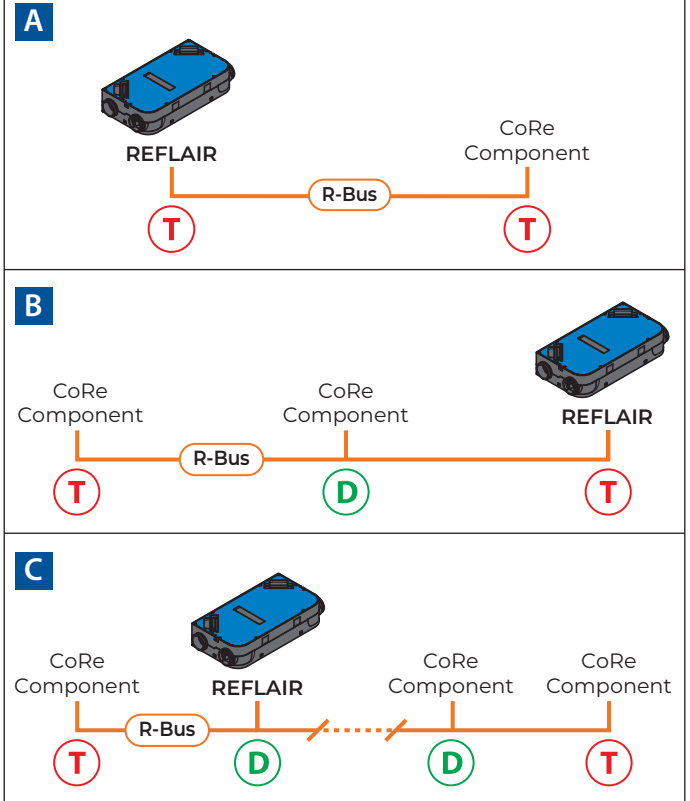

TERMINATION R-BUS (SWITCH SW3)

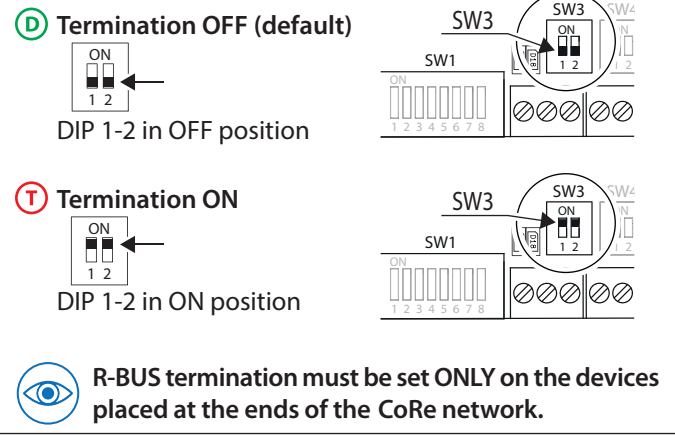

POSSIBLE INSTALLATION CONFIGURATIONS

Below we list the possible airflow configurations for the installation of REFLAIR in horizontal ceiling or vertical wall versions. The unit is supplied with FACTORY configuration. The reversal of flows, called REVERSE configuration, is obtained by setting DIP 2 Switch SW1 to ON position (see WIRING DIAGRAM on page 12).

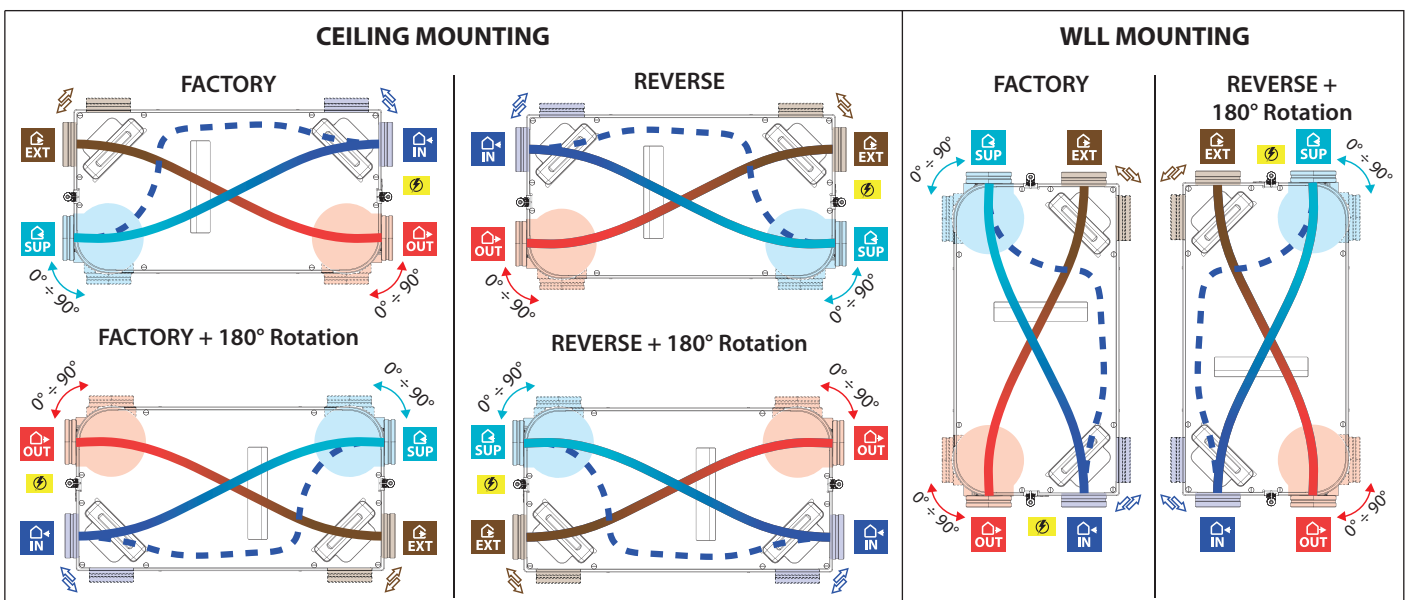

TECHNICAL DATA SHEET

INSTRUCTION FOR POSITIONING AND FIXING

CAUTION

- Installation and maintenance must be carried out by qualified personnel only. Throughout installation, make sure that the equipment is not connected to the electrical mains.
- It shall be installed only inside the building.

Positioning indication

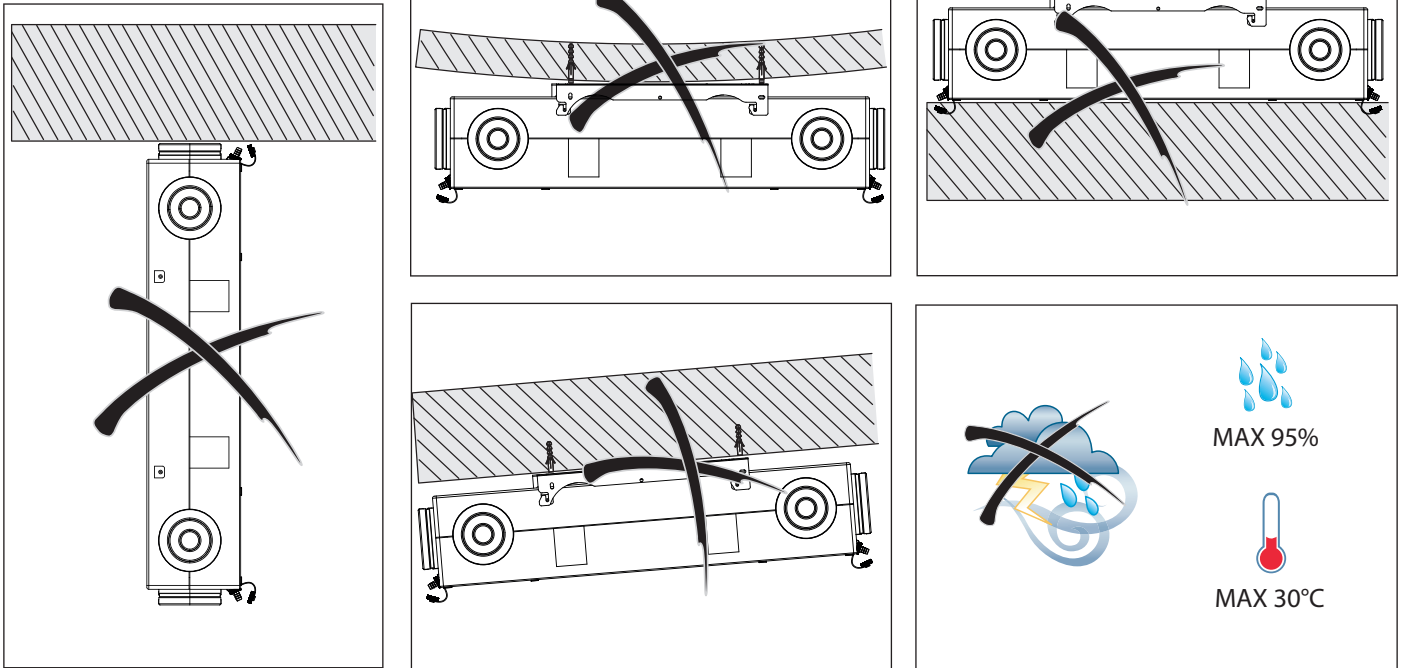

CORRECT POSITIONING

Position the machine on the ceiling or wall as indicated, use the supplied brackets to secure the unit. Install with an inclination of 2% (approx. 2 cm) towards the condensate outlet, at the stale air outlet to the outside. When installing the REFLAIR on the wall, keep the ejection flow (OUT) pointing downwards.

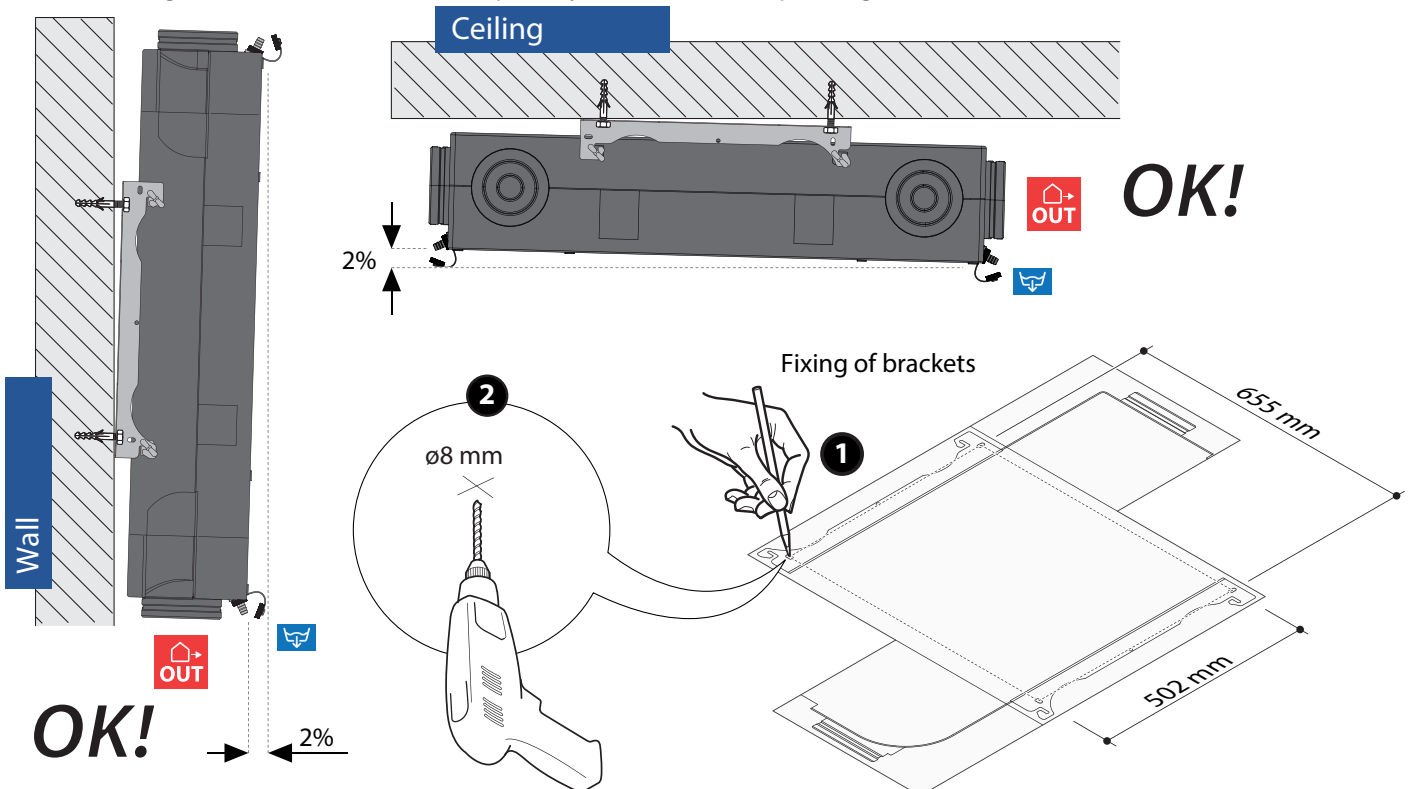





TECHNICAL DATA SHEET

CEILING INSTALLATION



IMPORTANT: provide the necessary space for the aeraulic connections and for their bends by ensuring that the minimum respect constraints of the unit are respected.

The minimum distances to be observed depend on the positioning of the connections and the position of the electrical panel and condensate drain. Maintain a minimum distance of 40 cm on all sides of the unit with the presence of the aeraulic connections (A1), otherwise 10 cm is sufficient (A2). For inspection and maintenance of the unit, ensure a distance of at least 30 cm in the presence of the switch cabinet (B), 15 cm in the presence of the condensate drain (B) and 60 cm at the front for cleaning the filters/recuperator (C).

Minimum space allowances

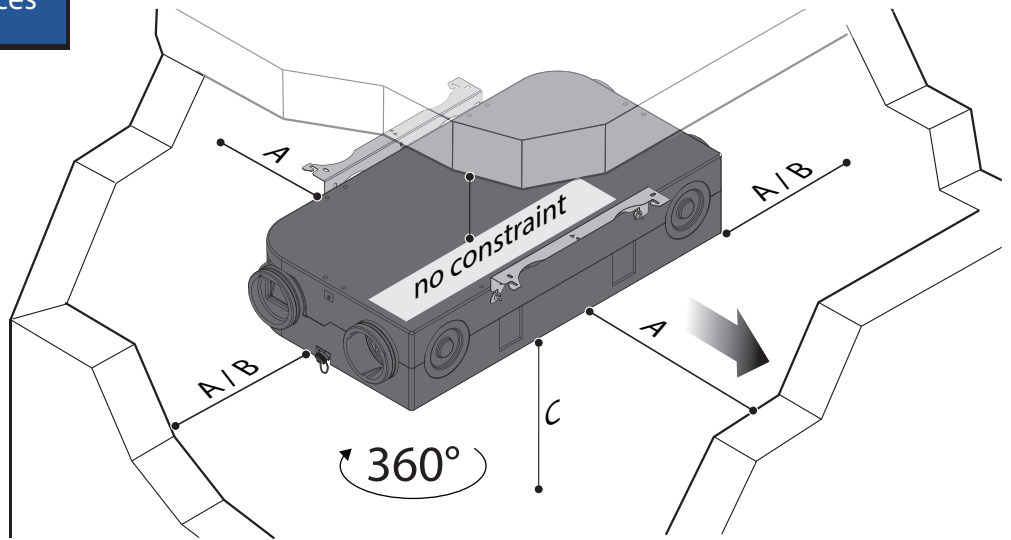
| | | | |
|---|---|----|------------|
| A |  | A1 | min. 40 cm |
| |  | A2 | min. 10 cm |
| B |  | | min. 30 cm |
| |  | | min. 30 cm |
| C |  | | min. 60 cm |



| A | | B |
|---|---|---|
|  |  |  |
| A1 | A2 | |
| min. 20 cm | min. 10 cm | min. 30 cm |



FALSE CEILING INSTALLATION

When installing the unit in a false ceiling, it is **MANDATORY** to create an inspection hatch for servicing the unit.

Inspection hatch

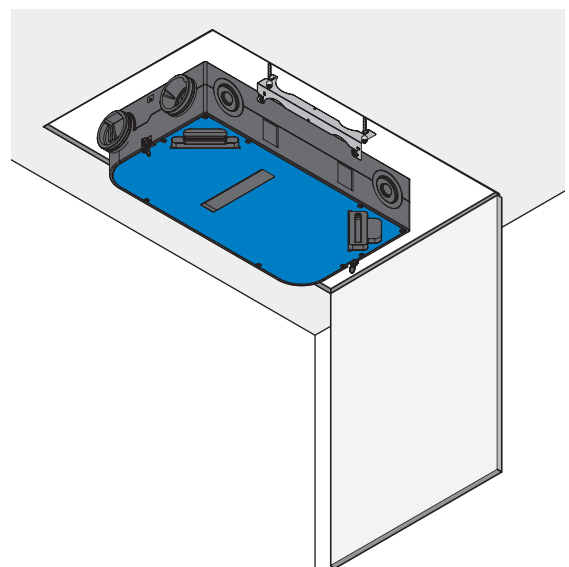
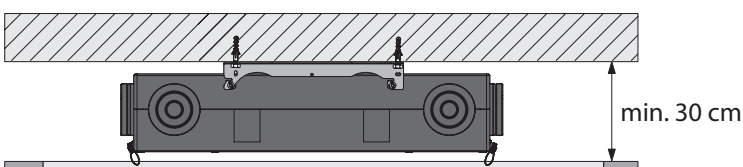
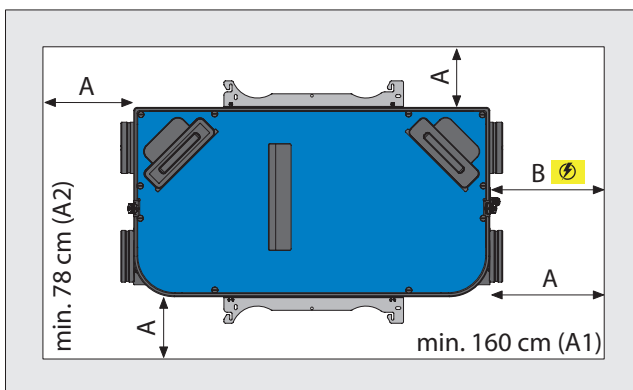

TECHNICAL DATA SHEET





WALL INSTALLATION

IMPORTANT: provide the necessary space for the aeraulic connections and for their bends by ensuring that the minimum respect constraints of the unit are respected.

Position the machine with condensate drain and stale air ejection (OUT) flow orientation facing downwards.

The minimum distances to be observed depend on the positioning of the connections and the position of the electrical panel and condensate drain. Maintain min. 40 cm on all sides of the unit with the presence of the aeraulic connections (A1), otherwise 10 cm is sufficient (A2). For inspection and maintenance of the unit, ensure a distance of at least 30 cm in the presence of the switch cabinet (B), 15 cm in the presence of the condensate drain (B) and 60 cm at the front for cleaning the filters/recuperator (C).

Minimum space allowances

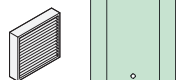
| A | | B | | C |
|---|---|---|---|---|
|  |  |  |  |  |
| A1 | A2 | min. 30 cm | min. 15 cm | min. 60 cm |
| min. 40 cm | min. 10 cm | | | |

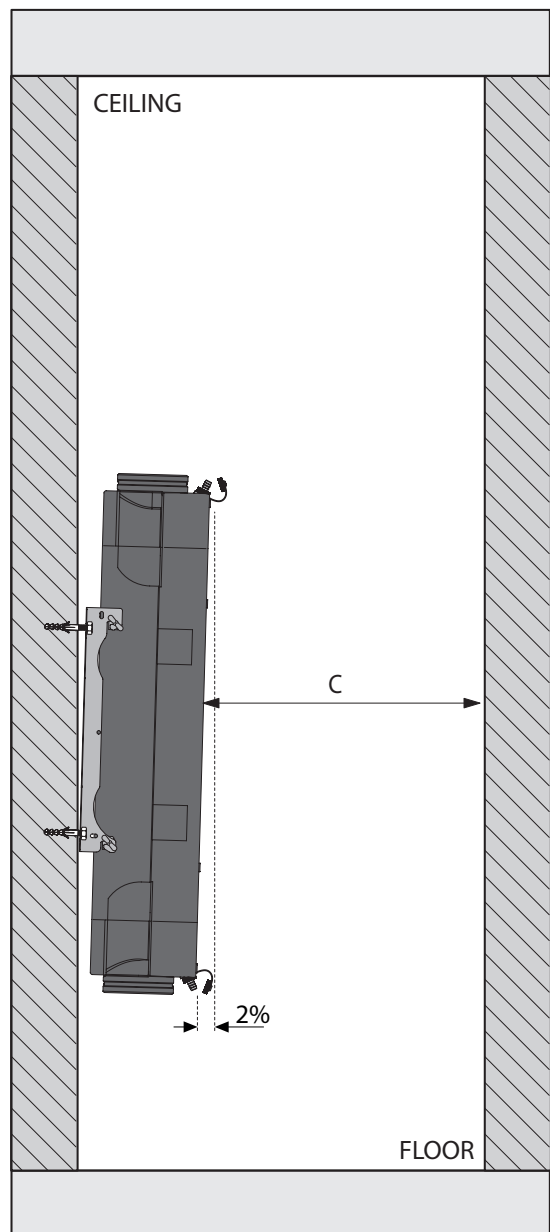
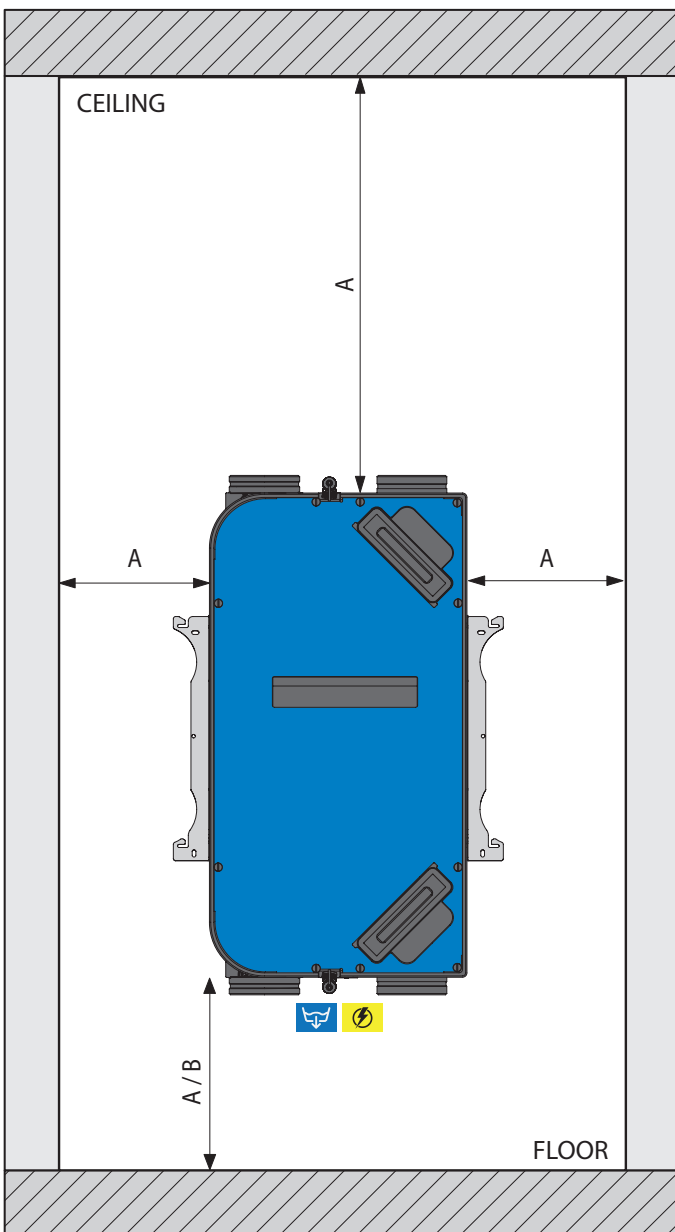

TECHNICAL DATA SHEET

MANDATORY KIT FOR DRAIN CONDENSATE

SF-P N

SF-M 13

Install the siphon on the drain line on the side corresponding to the connection of the outside air pipe (OUT-IN). Use the supplied kits, screwing the hose connector on the discharge side (\varnothing 14 mm) and the plug ($3/4''$ F) on the opposite side.

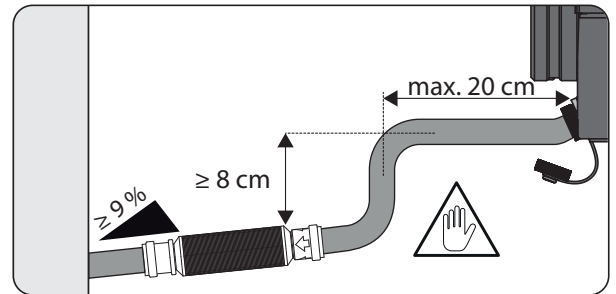
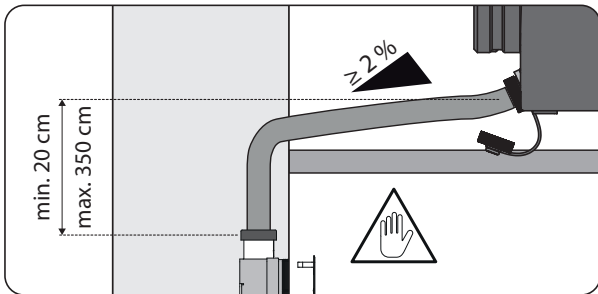
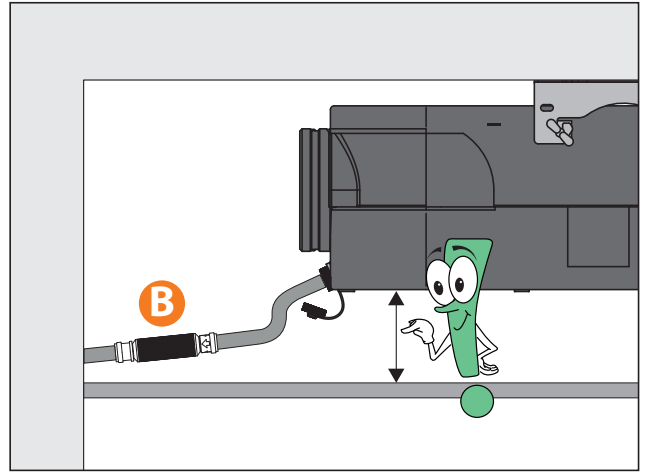
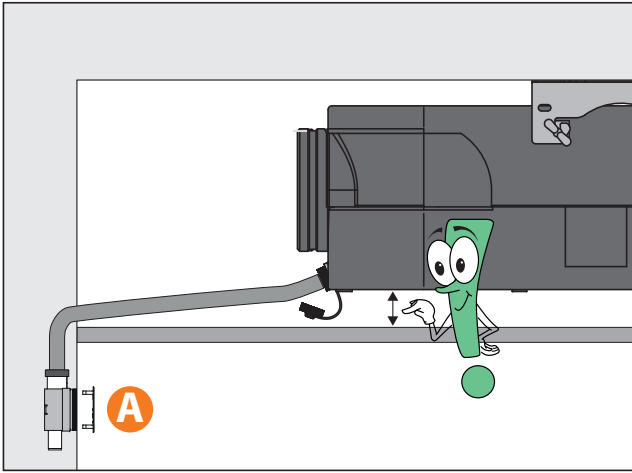

EXCHANGER EFFICIENCY

According to standard: UNI EN 13141

REFLAIR 150 - 250

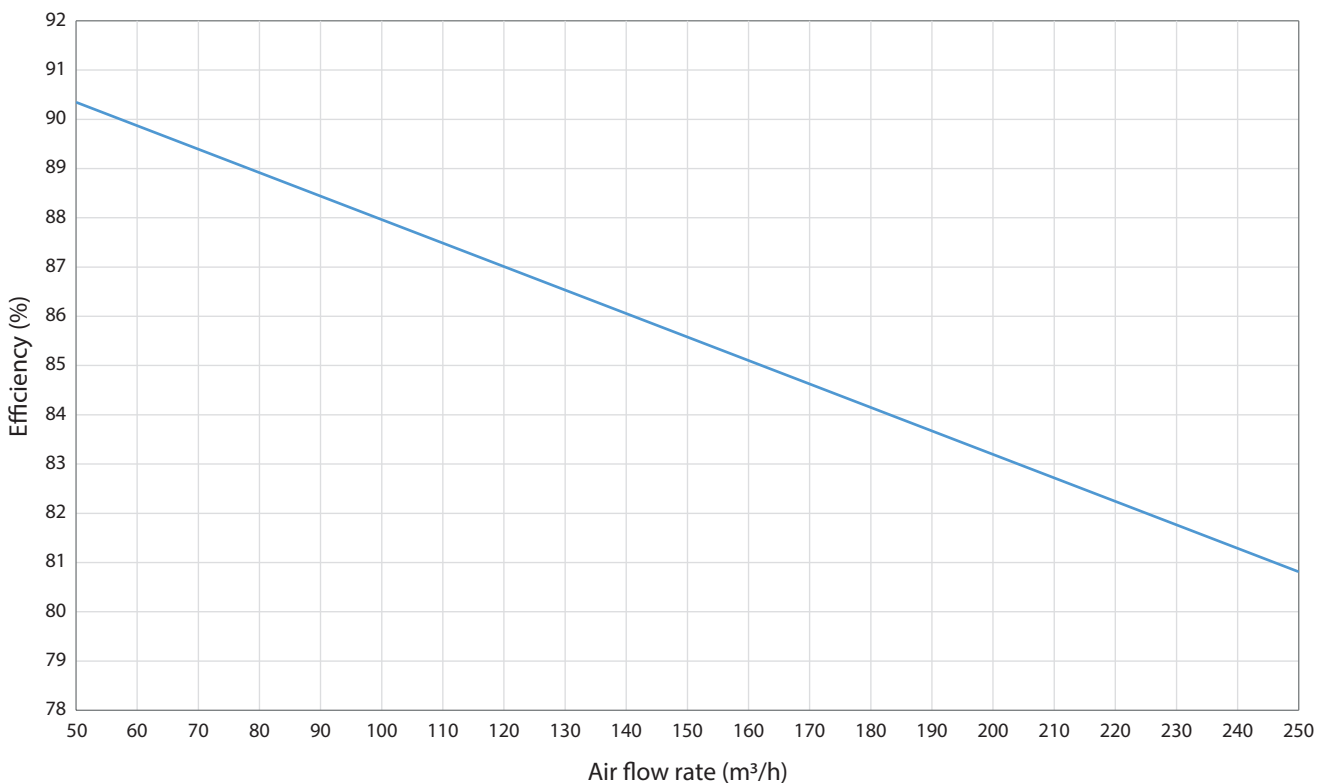

TECHNICAL DATA SHEET

AEREAULIC PERFORMANCE

REFLAIR 150

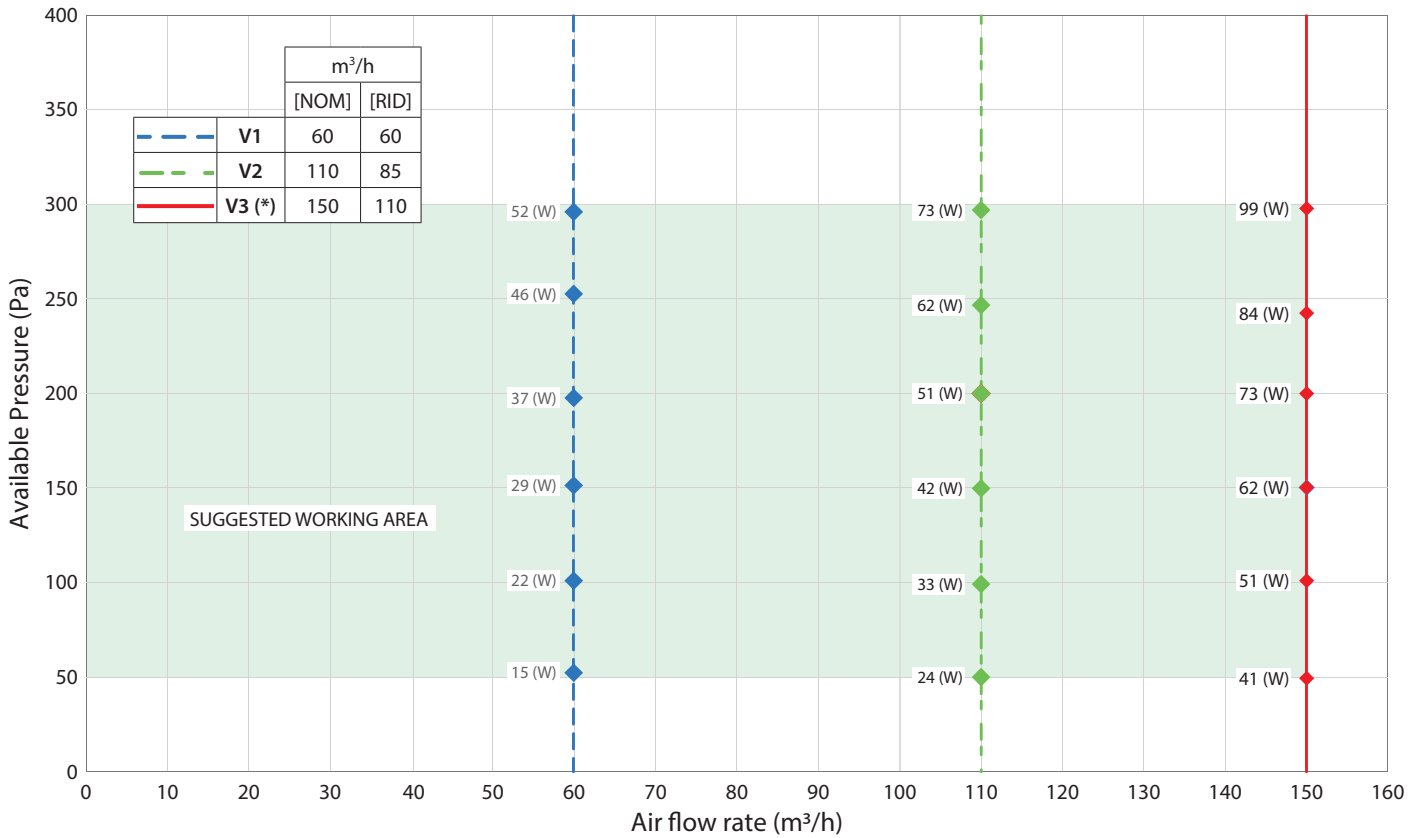

REFLAIR 250

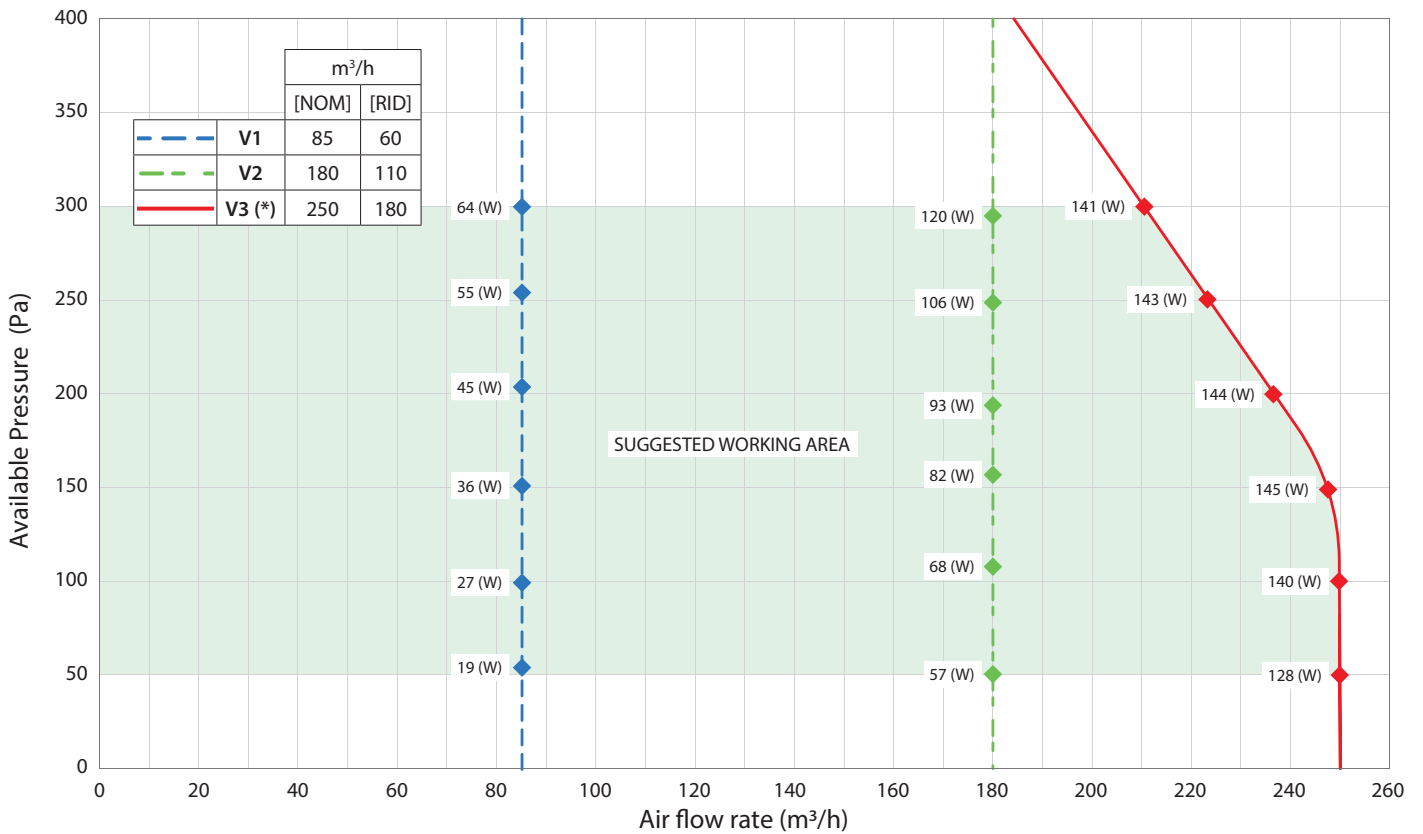

NOMINAL [NOM] AND REDUCED [RID] AIR FLOW RANGES

On installations with a 3-speed controller, a reduced flow rate range can be set via Dip Switch.

(*) Speed V3 (BOOST) is timed with a default of 15 min. and can be activated if environmental conditions require it.

TECHNICAL DATA SHEET

ACOUSTIC PERFORMANCE

REFLAIR 150 | Sound Power Levels

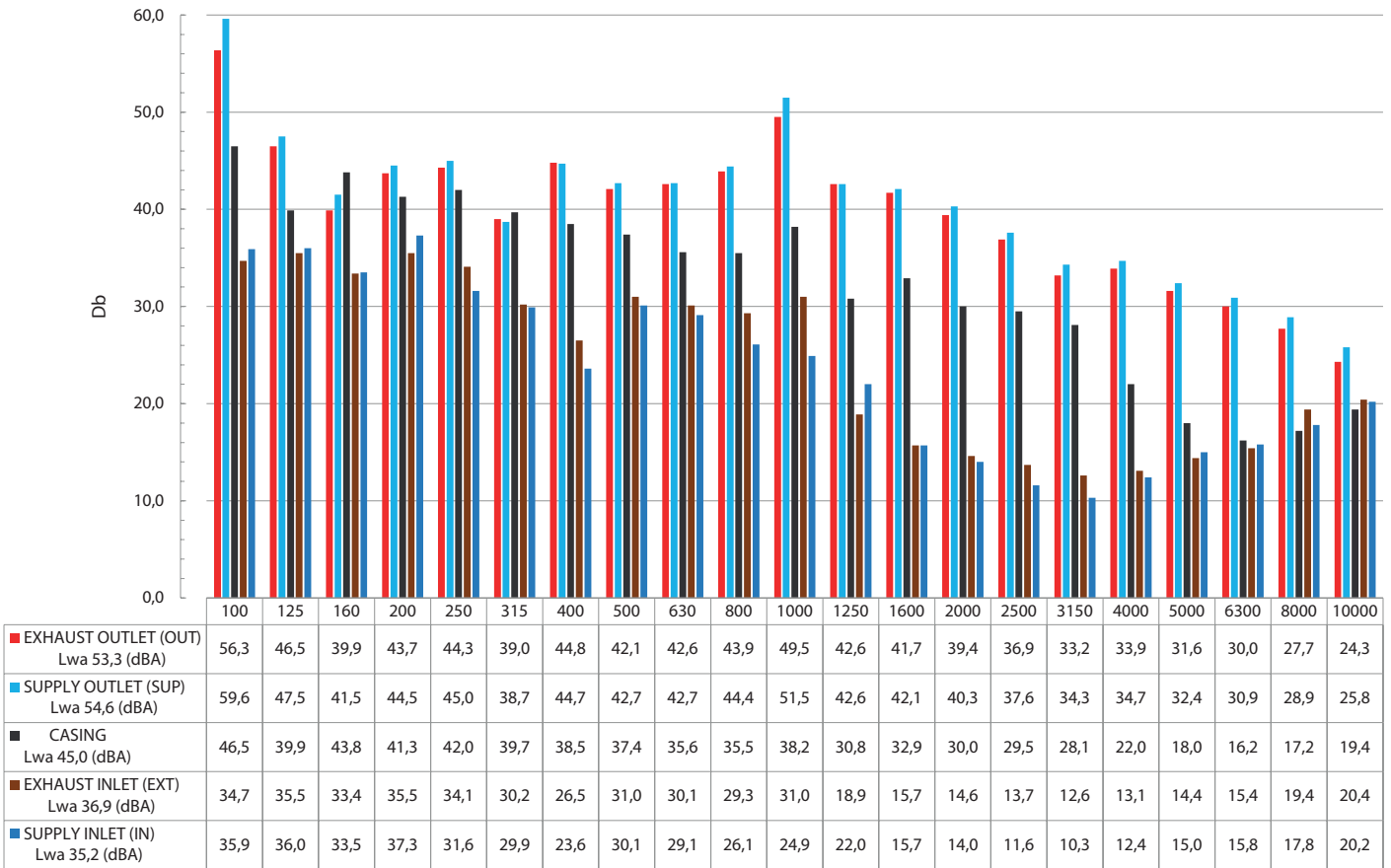

REFLAIR 250 | Sound Power Levels

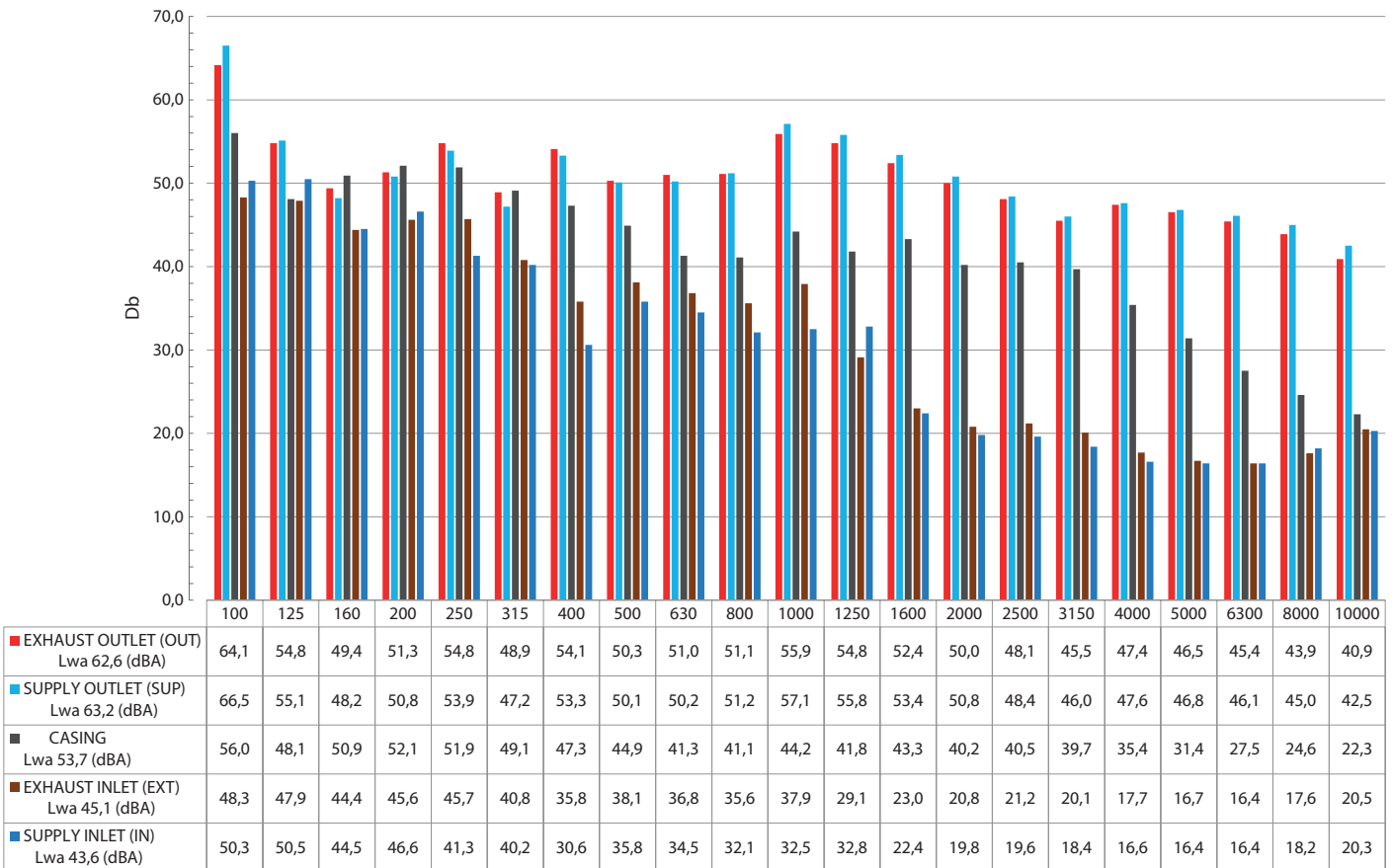

TECHNICAL DATA SHEET

PERFORMANCE ACCORDING TO COMMISSION REGULATION (UE) NO 1254/2014

European Union Commission Regulation (EU) No 1254/2014

Ecodesign Requirements for Ventilation Units

Annex IV Information requirements [fiche] for RVUs as referred to in Article 4(1)

a) Manufacturer: RDZ S.p.A.

b) Model: REFLAIR 150

c) Specific Energy Consumption (SEC) kWh/(m²a) and Class:

| | Control typology and CTRL factor | | | | | | | |
|---------|----------------------------------|-------|-------|-------|----------------|-------|--------------|-------|
| | Manual | | Clock | | Central demand | | Local demand | |
| | 1 | | 0,95 | | 0,85 | | 0,65 | |
| | SEC | Class | SEC | Class | SEC | Class | SEC | Class |
| Cold | -75,1 | A+ | -76,0 | A+ | -77,8 | A+ | -81,2 | A+ |
| Average | -37,3 | A | -38,0 | A | -39,5 | A | -42,2 | A+ |
| Warm | -13,0 | E | -13,7 | E | -14,9 | E | -17,2 | E |

d) Article 2 typology:

I) Residential Ventilation Unit (RVU)

II) Bidirectional (BVU)

e) Drive Variable speed drive

f) Recuperative heat exchanger

g) Thermal efficiency of heat recovery 87,8% at reference flow rate

h) Maximum flow rate 150 m³/h at 100 Pa. This unit is for residential use only

i) Power input at maximum flow rate 51 W

j) Sound power level (LWA) 45 dB

k) Reference flow rate 0,0287 m³/s

l) Reference pressure difference 50 Pa

m) Reference Specific Power Input (SPI) 0,2355 W/(m³/h)

n) See c)

o) Leakage rates at reference flow rate

I) Maximum internal 5,1 %

II) Maximum external 4,7 %

p) Not applicable

q) Filter alarm reset via room controller

r) Not applicable

s) Recycling disassembly instruction - go to www.rdz.it

t) Not applicable

u) Not applicable

v) Annual electricity consumption (AEC) (in kWh electricity/a)

| | Control typology and CTRL factor | | | |
|---------|----------------------------------|-------|----------------|--------------|
| | Manual | Clock | Central demand | Local demand |
| | 1 | 0,95 | 0,85 | 0,65 |
| Cold | 877 | 855 | 813 | 737 |
| Average | 340 | 318 | 276 | 200 |
| Warm | 295 | 273 | 231 | 155 |

w) The annual heating saved (AHS) (in kWh primary energy/a)

| | Control typology and CTRL factor | | | |
|---------|----------------------------------|-------|----------------|--------------|
| | Manual | Clock | Central demand | Local demand |
| | 1 | 0,95 | 0,85 | 0,65 |
| Cold | 8826 | 8864 | 8940 | 9092 |
| Average | 4512 | 4531 | 4570 | 4648 |
| Warm | 2040 | 2049 | 2067 | 2102 |

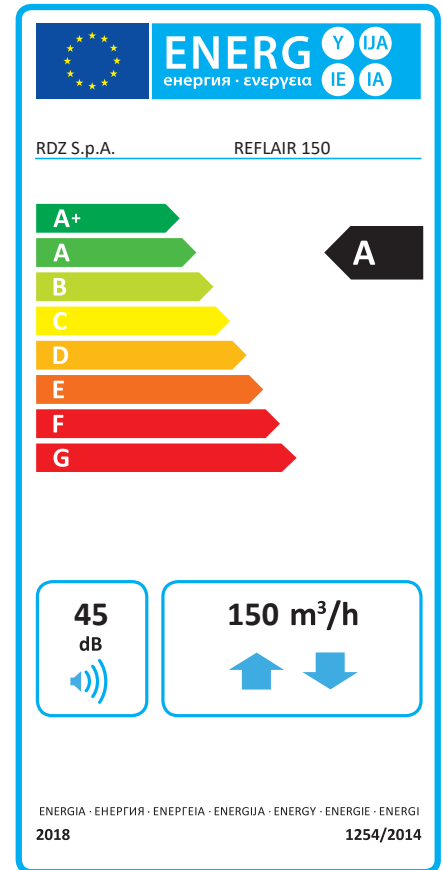

TECHNICAL DATA SHEET

PERFORMANCE ACCORDING TO COMMISSION REGULATION (EU) NO 1254/2014

European Union Commission Regulation (EU) No 1254/2014

Ecodesign Requirements for Ventilation Units

Annex IV Information requirements [fiche] for RVUs as referred to in Article 4(1)

a) Manufacturer: RDZ S.p.A.

b) Model: REFLAIR 250

c) Specific Energy Consumption (SEC) kWh/(m²a) and Class:

| | Control typology and CTRL factor | | | | | | | |
|---------|----------------------------------|--------|-------|--------|----------------|--------|--------------|--------|
| | Manual | | Clock | | Central demand | | Local demand | |
| | 1 | | 0,95 | | 0,85 | | 0,65 | |
| | SEC | Classe | SEC | Classe | SEC | Classe | SEC | Classe |
| Cold | -69,0 | A+ | -70,3 | A+ | -72,9 | A+ | -77,8 | A+ |
| Average | -32,3 | B | -33,4 | B | -35,5 | A | -39,4 | A |
| Ward | -8,7 | F | -9,6 | F | -11,5 | E | -14,8 | E |

d) Article 2 typology:

I) Residential Ventilation Unit (RVU)

II) Bidirectional (BVU)

e) Drive Variable speed drive

f) Recuperative heat exchanger

g) Thermal efficiency of heat recovery 84,2 % at reference flow rate

h) Maximum flow rate 250 m³/h. This unit is for residential use only

i) Power input at maximum flow rate 140 W

j) Sound power level (LWA) 54 dB

k) Reference flow rate 0,0497 m³/s

l) Reference pressure difference 50 Pa

m) Reference Specific Power Input (SPI) 0,3570 W/(m³/h)

n) See c)

o) Leakage rates at reference flow rate

I) Maximum internal 3 %

II) Maximum external 2,8 %

p) Not applicable

q) Filter alarm reset via room controller

r) Not applicable

s) Recycling disassembly instruction - go to www.rdz.it

t) Not applicable

u) Not applicable

v) Annual electricity consumption (AEC) (in kWh electricity/a)

| | Control typology and CTRL factor | | | |
|---------|----------------------------------|-------|----------------|--------------|
| | Manual | Clock | Central demand | Local demand |
| | 1 | 0,95 | 0,85 | 0,65 |
| Cold | 1029 | 996 | 932 | 816 |
| Average | 492 | 459 | 395 | 279 |
| Warm | 447 | 414 | 350 | 234 |

w) The annual heating saved (AHS) (in kWh primary energy/a)

| | Control typology and CTRL factor | | | |
|---------|----------------------------------|-------|----------------|--------------|
| | Manual | Clock | Central demand | Local demand |
| | 1 | 0,95 | 0,85 | 0,65 |
| Cold | 8602 | 8651 | 8750 | 8947 |
| Average | 4397 | 4422 | 4473 | 4573 |
| Warm | 1988 | 2000 | 2022 | 2068 |

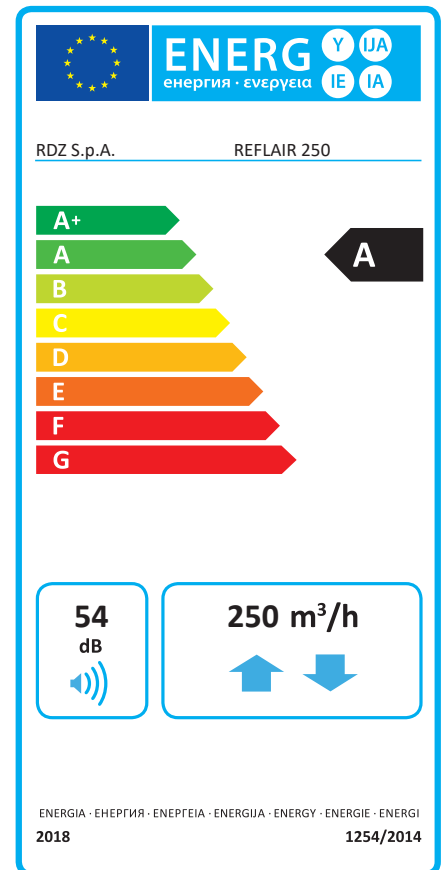

TECHNICAL DATA SHEET

FASOCB000AB.02
02/2025

REFLAIR 150-250 SCHEMA ELETTRICO - WIRING DIAGRAM

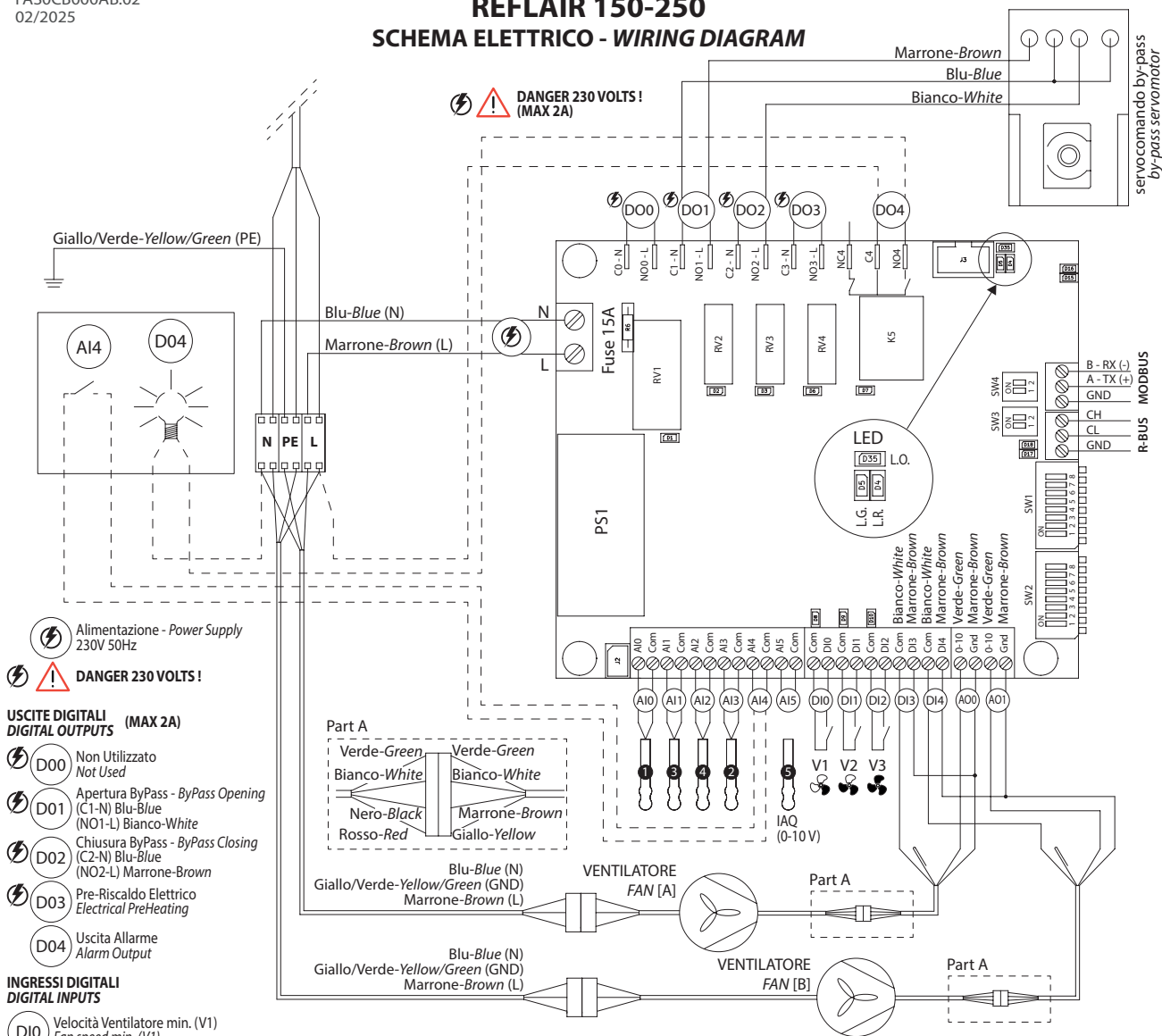

Alimentazione - Power Supply
230V 50Hz

DANGER 230 VOLTS!

USCITE DIGITALI DIGITAL OUTPUTS (MAX 2A)

- D00** Non Utilizzato - Not Used
- D01** Apertura ByPass - ByPass Opening (C1-N) Blu-Blue (NO1-L) Bianco-White
- D02** Chiusura ByPass - ByPass Closing (C2-N) Blu-Blue (NO2-L) Marrone-Brown
- D03** Pre-Riscaldamento Elettrico - Electrical PreHeating
- D04** Uscita Allarme - Alarm Output

INGRESSI DIGITALI DIGITAL INPUTS

- DI0** Velocità Ventilatore min. (V1) - Fan speed min. (V1)
- DI1** Velocità Ventilatore med. (V2) - Fan speed med. (V2)
- DI2** Velocità Ventilatore max. (V3) - Fan speed max (V3)
- DI3** [A] Ventilatore - Fan (Com) Bianco-White (DI3) Marrone-Brown
- DI4** [B] Ventilatore - Fan (Com) Bianco-White (DI4) Marrone-Brown

USCITE ANALOGICHE ANALOGUE OUTPUTS

- AO0** [A] Ventilatore - Fan (0-10) Verde-Green (Gnd) Marrone-Brown
- AO1** [B] Ventilatore - Fan (0-10) Verde-Green (Gnd) Marrone-Brown

INGRESSI ANALOGICI ANALOGUE INPUTS

- AI0** Sonda-Probe 1 (Com) (AI0) Nero-Black
- AI1** Sonda-Probe 3 (Com) (AI1) Nero-Black
- AI2** Sonda-Probe 4 (Com) (AI2) Nero-Black
- AI3** Sonda-Probe 2 (Com) (AI3) Nero-Black
- AI4** Reset Allarme Filtri - Filters Alarm Reset
- AI5** Sonda Qualità Aria Amb. (*) 5 Indoor Air Quality Probe (*) *Se Presente - If present

SWITCH SW1 (default)

DIP 1 SELETTORE FLUSSO ARIA-AIR FLOW SELECTOR
OFF= Portate Aria Nominale-Nominal Flow Rates
ON= Portate Aria Ridotte-Reduced Flow Rates

DIP 2 SELETTORE CONFIG.-CONFIGURATION SELECTOR
OFF= FACTORY
ON= REVERSE

DIP 2 OFF | FACTORY MODE

- 1 (AI0) SUP | Immissione Aria-Supply Air
- 3 (AI1) IN | Ingresso Aria Esterna-Air Inlet
- 4 (AI2) EXT | Estrazione Aria-Air Extraction
- 2 (AI3) OUT | Espulsione Aria-Exhaust Air

- [A] Ventilatore - Fan SUP | Immissione Aria-Supply Air
- [B] Ventilatore - Fan OUT | Espulsione Aria-Exhaust Air

DIP 2 ON | REVERSE MODE

- 1 (AI0) OUT | Espulsione Aria-Exhaust Air
- 3 (AI1) EXT | Estrazione Aria-Air Extraction
- 4 (AI2) IN | Ingresso Aria Esterna-Air Inlet
- 2 (AI3) SUP | Immissione Aria-Supply Air

- [A] Ventilatore - Fan OUT | Espulsione Aria-Exhaust Air
- [B] Ventilatore - Fan SUP | Immissione Aria-Supply Air

DIP 3
OFF= Recuperatore standard - Standard exchanger
ON= Recuperatore entalpico - Enthalpic exchanger

DIP 4
OFF= (AI5) 0-10 V Disabilitato - Disabled
ON= (AI5) 0-10 V Abilitato - Enabled

DIP 5-6-7
Non Utilizzato - Not Used

DIP 8
MODBUS - Gestione Portate Aria - Air Flow Manag.
OFF= % | ON= m³/h (Wi-KNX)

SWITCH SW2 (default)

DIP 1-2-3-4-5-6 INDIRIZZO MODBUS-MODBUS ADDRESS
DEFAULT: 9 (DIP 1 ON, DIP 4 ON)

DIP 7 VELOCITÀ TRASMISSIONE BAUD RATE
OFF= 19200 Bit/s (Wi-KNX)
ON= 9600 Bit/s

DIP 8 NR. BIT STOP-NR. OF STOP BITS
OFF= 2 Bit Stop
ON= 1 Bit Stop (KNX)

SWITCH SW3 (default)

R-BUS
Terminazione Linea Line termination
OFF= DIP (1-2) OFF
ON= DIP (1-2) ON

SWITCH SW4 (default)

MODBUS
Terminazione Linea Line termination
OFF= DIP (1-2) OFF
ON= DIP (1-2) ON

ALLARMI E SEGNALAZIONI - ALARMS AND SIGNALLING

- LED** (D5 L.G.) Verde-Green | Led Funzionamento-Operation Led
- (D35 L.O.) Arancione-Orange | Led Allarmi-Alarms Led
- (D4 L.R.) Rosso-Red | Led Errori-Errors Led

| Tipo Type | Descrizione Description | Nr. Lampeggi Nr. of flashes |
|---------------------------|---|-----------------------------|
| D5 L.G. Verde Green | Modalità Economy - Economy mode | 1 |
| | Modalità Rinnovo - Renewal mode | 2 |
| | Modalità Boost - Boost mode | 3 |
| | Modalità Sbrinamento - Defrost mode | 4 |
| D35 L.O. Arancione Orange | Allarme Sonda - Probe Alarm 1 | 1 |
| | Allarme Sonda - Probe Alarm 3 | 2 |
| | Allarme Sonda - Probe Alarm 4 | 3 |
| | Allarme Sonda - Probe Alarm 2 | 4 |
| | Allarme Sonda Qualità Aria - Air Quality Probe Alarm 5 | 5 |
| D4 L.R. Rosso Red | Malfunzionamento Ventilatore (A) - Fan (A) Malfunction | 1 |
| | Malfunzionamento Ventilatore (B) - Fan (B) Malfunction | 2 |
| | Segnalazione Filtri Sporchi - Dirty Filter Warning | 3 |
| | Blocco Macchina Filtri Sporchi - Machine Lock Dirty Filters | 4 |



RDZ S.p.A. V.le Trento, 101 - 33077 SACILE (PN) - Italy

Tel. +39 0434.787511 Fax +39 0434.787522

info@rdz.it www.rdz.it

FAC0CB026BZ.04

02/2025

COMPANY WITH
QUALITY SYSTEM
CERTIFIED BY DNV
ISO 9001

CLICK I SCAN



qr.rdz.it/?qr=P626